

# Ni-Cd VNT D U 4200



ARTS Energy's VNT U high temperature Ni-Cd series are perfectly suited to emergency and security equipment applications. It is designed to accept a permanent charge for a minimum of 4 years in high temperature environments (up +55°C).

To meet customers' requirements, ARTS Energy provides **custom-designed and standardised battery packs**.

For your battery design and system needs, please **contact ARTS Energy**.



## ELECTRICAL CHARACTERISTICS

• Nominal voltage (V)	1.2
• IEC minimum capacity (mAh)*	4200
• IEC designation	KRMU 33/60
• Impedance at 1000 Hz (mΩ)	Less than 20 mΩ

\* Charge 16 h at C/10, discharge at C/5.

## DIMENSIONS

• Diameter (mm)	32.15 ± 0.1
• Height (mm)	59.65 ± 0.15
• Top projection (mm)	0.9 ± 0.1
• Top flat area diameter (mm)	9.95 ± 0.1
• Weight (g)	110

Dimensions are given for bare cells.

## CHARGE CONDITIONS

	Temp. (°C)	Current	
• Standard (16h)	+0 to +55	C/10	
• Permanent	+0 to +55	C/20	9.95

## DISCHARGE CONDITIONS

• Standard C/5	840 mA	End of discharge voltage 1V/cell
• Max continuous current	4.2 A	End of discharge voltage 1V/cell

## CYCLING CONDITIONS

• ELU applications	1 discharge / month MAX
• Back up applications	Consult ARTS Energy

The operation of the battery must strictly be in accordance with ARTS Energy technical recommendations, to obtain the performances stated by ARTS Energy.

Data is given for single cells. Please consult ARTS Energy for utilisation of cells outside specification.

Data in this document is subject to change without notice and become contractual only after written confirmation by ARTS Energy



## APPLICATIONS

- Emergency lighting
- Back-up systems
- Security devices

## MAIN BENEFITS

- Superior robustness
- Good charge efficiency at high temperature
- Permanent charge
- Longer life duration

## TYPICAL DIMENSIONS

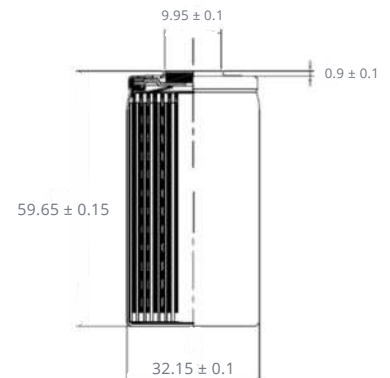

Typical dimensions (mm). Without tube.

## STORAGE

Recommended: +5°C to +25°C

Relative humidity: 65 ± 5 %